

JET FANS (BASEMENT CAR PARKING)

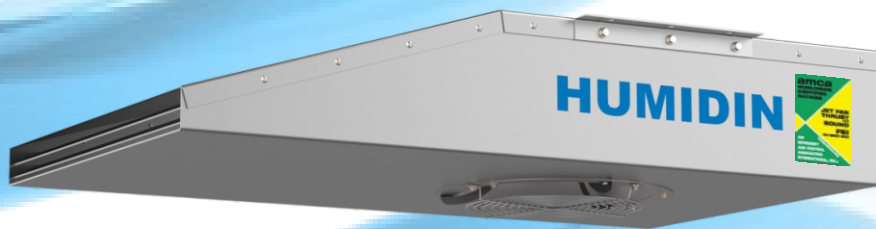

MEMBER

Quality Speaks For Itself



NON SPHERICAL JET FAN



CENTRIFUGAL JET FAN



AXIAL JET FAN

FIRE RATED ARE CERTIFIED FOR (FROM 250°C TO 400°C FOR 2 HRS)

HUMIDIN BASEMENT CAR PARKING / TUNNEL VENTILATION (CAR/METRO) is a critical system used in transportation tunnels, to maintain air quality, control temperature, and ensure the safety of passengers and drivers. These tunnels are typically enclosed spaces where air circulation is limited, and effective ventilation systems are required to manage the buildup of pollutants, heat, smoke, and harmful gases such as carbon monoxide (CO), nitrogen dioxide (NO), and particulate matter.

FEATURES:

- 1. Blades(Axial/Non Spherical Jet Fans)**
Tunnel jet fans that are designed with 100% reversible blades. The term "100% reversible" indicates that the fan blades can change their orientation, ensuring that the fan can provide full airmovement in either direction, depending on the need.
- 2. Blades(Centrifugal Jet Fans)**
The blades are designed to handle higher Thrust, which makes them suitable for use in complex air distribution systems where airmovement must overcome resistance, such as in tunnels or large facilities.
- 3. Air Quality Control:**
Tunnel ventilation systems help ensure that air quality remains safe by controlling the concentration of gases like carbon monoxide (CO) and nitrogen oxides (NO), which are produced by vehicle exhaust. This is particularly important in road tunnels where a large number of vehicles continuously generate exhaust gases.
- 4. Efficient Air Movement:**
Tunnel ventilation systems often use axial fans, centrifugal fans, or jet fans to create efficient Air moves through the tunnel. Jet fans (including Non Spherical Jet Fans) are commonly used in tunnels for their ability to push air in a Focused stream, helping to move smoke, pollutants, and hot air effectively.

5. Energy Efficiency:

Tunnel ventilation systems are designed to operate efficiently, often incorporating energy-saving features like variable speed drives for fans, smart sensors, and automated control systems. These systems adjust fan speeds and ventilation levels based on the actual air quality and traffic conditions to reduce energy consumption.

COMPUTATIONAL FLUID DYNAMICS (CFD)

Computational Fluid Dynamics (CFD) for metro ventilation is a powerful tool used to simulate and analyze air movement, temperature distribution, and air movement dynamics within metro systems, including stations, tunnels, and ventilation shafts. CFD helps optimize ventilation designs, improve safety, enhance comfort, and ensure compliance with regulations related to air quality, smoke extraction, and energy efficiency in metro systems.

APPLICATIONS

- Road Tunnels:
- Metro/Urban Rail Tunnels:
- Mining Tunnels:
- Basement Car Parking:

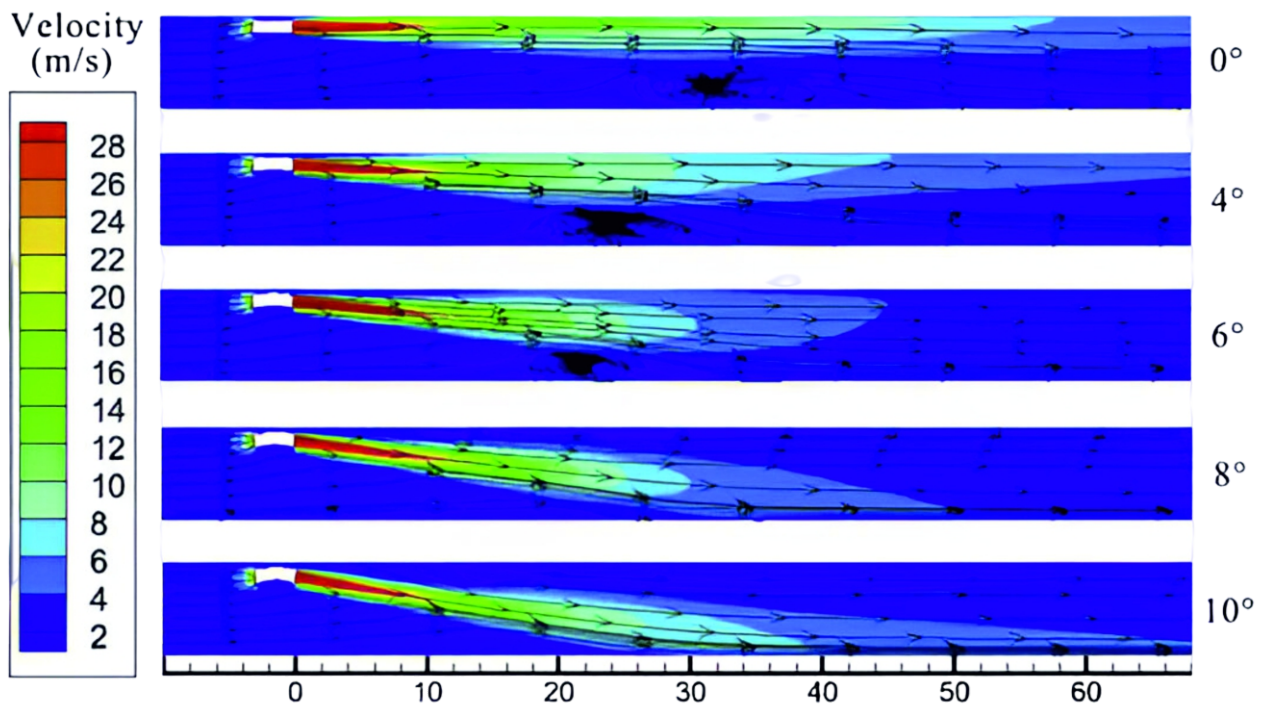

LONGITUDINAL VENTILATION

Longitudinal ventilation system

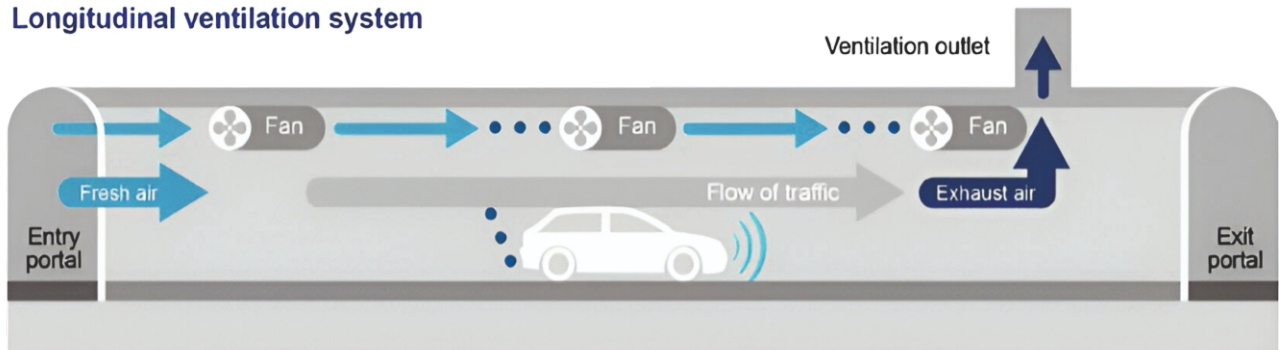

In longitudinal ventilation, the Air moves is directed along the length of the tunnel using jet fans or other fans placed along the tunnel. This system moves air in the same direction as traffic flow, helping to clear pollutants and maintain a steady Air moves. It is often used in road tunnels and can also serve as an effective method of smoke control during emergency.

TRANSVERSE VENTILATION

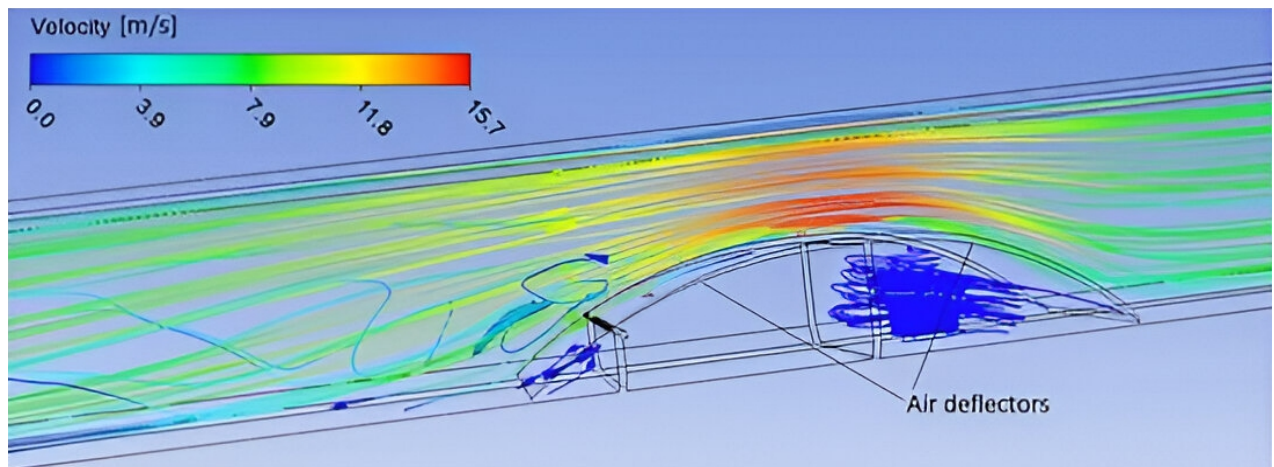

This system uses fans placed at regular intervals along the tunnel's ceiling or walls to blow air directly across the tunnel. Transverse ventilation is often used in metro tunnels, where Air moves must be directed over a short distance to ensure consistent air quality and temperature. Exhaust shafts or ventilation buildings are typically used to expel stale air.

DIMENSIONS TABLE OF CENTRIFUGAL JET FANS

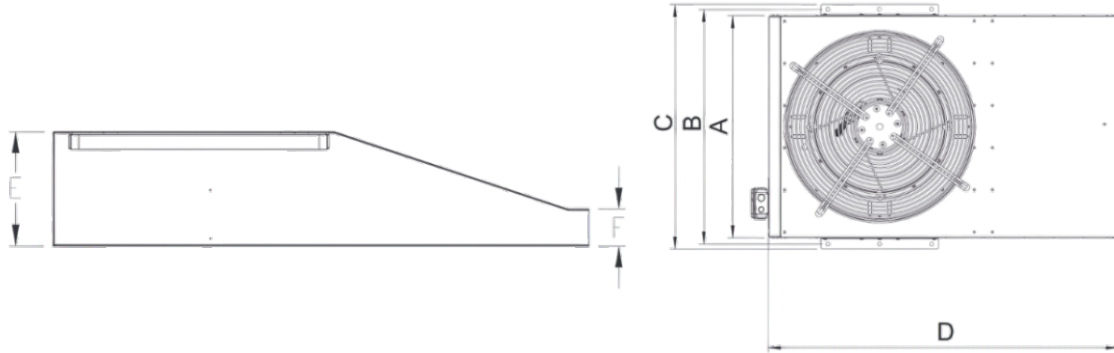

CENTRIFUGAL JET FAN												
Air Volume	Thrust	Fan	Motor	Speed	Sound	Temperature	A	B	C	D	E	F
CMH	N	Model	Kw	RPM	dB@3m	Degree Celcius	mm	mm	mm	mm	mm	mm
7400/4250	50/18	ACI-50	1.5/0.37	1427/729	70/50	250 / 300 / 400	810	900	980	1342	312	115
9700/4900	75/20	ACI-75	2.3/0.37	1427/729	72/50	250 / 300 / 400	930	1020	1100	1605	355	115
13662/6908	88 / 22.5	ACI-100	3.0/0.5	1427/729	75/55	250 / 300 / 400	1010	1100	1182	1670	355	115

NOTE: ALL TECHNICAL & DIMENSIONS ARE ONLY FOR REFERENCE

DIMENSIONS TABLE OF AXIAL JET FANS

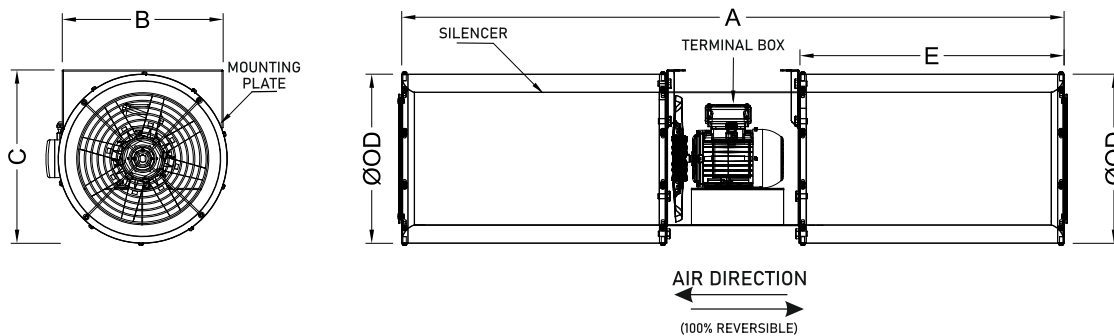

AXIAL JET FAN (100% REVERSIBLE)												
Air Volume	Thrust	Fan Model	Fan Dia	Motor	Speed	Sound	Temperature	2D SILENCER				
								A	B	C	ØOD	E
CMH	N	Model	mm	Kw	RPM	dB@1m	Degree Celcius	mm	mm	mm	mm	mm
2700/5400	30	ACJF 315	315	0.24/1.2	1440/2828	47/62	250 / 300 / 400	1580	384	410	400	630
3780/7560	53	ACJF 355	355	0.34/1.7	1437/2870	52/67	250 / 300 / 400	1740	417	450	440	710
4675/9350	70	ACJF 400	400	0.34/1.7	1450/2900	57/72	250 / 300 / 400	1920	463	495	485	800

NOTE: ALL TECHNICAL & DIMENSIONS ARE ONLY FOR REFERENCE

DIMENSIONS TABLE OF NON SPHERICAL JET FAN

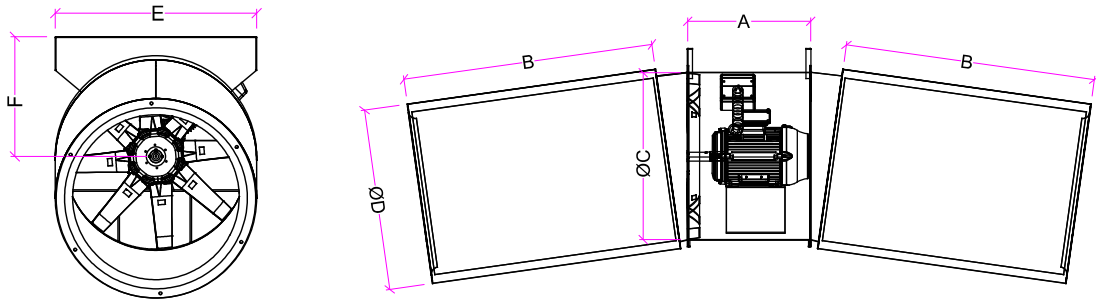

100% REVERSIBLE NON SPHERICAL JET FAN WITH 1.5 D SILENCER							
MODEL	DIAMETER	A	B	ØC	ØD	E	F
NSJF -710	710	681	1065	710	795	795	500
NSJF -800	800	681	1200	800	885	885	545
NSJF -900	900	670	1350	900	985	985	595
NSJF -1000	1000	737	1500	1000	1085	1085	645
NSJF -1120	1120	764	1680	1120	1205	1205	705
ALL DIMENSIONS ARE ONLY FOR REFERENCE							
ALL DIMENSIONS IN (mm)							

TECHNICAL DATA SHEET FOR NON SPHERICAL JET FAN									
100% REVERSIBLE NON SPHERICAL JET FAN									
Model Name	Fan DIA (mm)	Motor Pole	MOC of Fan Casing	MOC of Silencer	Nominal Thrust (N)	Motor Power kW at 50 Hz	Motor Power HP at 50 Hz	Sound Power Level (dBA)	dBA after Both Side Silencer at 1.5D
NSJF 710	710	2	HOT DIPPED GALVANIZED	GI	445	15	20	101	89
					547	22	30	102	90
					670	30	40	104	92
					745	34	50	105	93
NSJF 800	800	2		GI	660	27	40	104	92
					775	30	40	105	93
					835	30	40	106	94
NSJF 800	800	4			GI	269	5.5	7.5	90
				318		7.5	10	92	80
				368		10	15	94	82
NSJF 900	900	4		GI		475	11	15	89
					520	13	20	90	78
					642	15	20	92	80
NSJF 1000	1000	4			GI	605	15	20	100
				725		18.5	25	102	90
				810		22	30	103	91
			915	27		40	104	92	
NSJF 1120	1120	4	GI	960	30	40	105	93	
				1020	22	30	104	92	
				1190	37	50	105	93	
				1250	45	60	106	94	



INLINE JET FAN

HUMIDIN INLINE JET FAN are used in **WAREHOUSES** to maintain air quality, control temperature, and ensure the safety of passengers and drivers. These warehouses are typically enclosed spaces where air circulation is limited, and effective ventilation systems are required to manage the buildup of pollutants, heat, smoke, and harmful gases such as carbon monoxide (CO), nitrogen dioxide (NO), and particulate matter.

FEATURES

- 1. High-Performance Ventilation System**
Humidin Inline Jet Fans are designed to provide effective ventilation in enclosed warehouse environments where natural air circulation is limited. They ensure continuous air movement to prevent the accumulation of pollutants and stale air.
- 2. Efficient Control of Harmful Gases**
These jet fans help in the dilution and removal of hazardous gases such as carbon monoxide (CO), nitrogen dioxide (NO₂), and airborne particulate matter, thereby maintaining safe air quality levels for personnel and vehicle operators.
- 3. Temperature and Heat Build-Up Control**
By promoting uniform airflow throughout the warehouse, the jet fan helps regulate internal temperatures and reduce heat buildup, improving comfort and operational efficiency.
- 4. Inline Compact Design**
The inline configuration allows easy integration into ventilation layouts while occupying minimal space. This design ensures optimal airflow performance with reduced pressure losses.
- 5. Low Noise and Vibration Operation**
Equipped with dynamically balanced impellers, the fans operate with low noise and minimal vibration, making them suitable for continuous operation in large enclosed spaces.
- 6. Energy-Efficient Performance**
Humidin Inline Jet Fans deliver high airflow at low power consumption, reducing overall energy costs and supporting sustainable building operations.

APPLICATIONS

- **Warehouses and Storage Facilities** for air quality maintenance and ventilation
- **Logistics and Distribution Centers** to control temperature and pollutant levels
- **Enclosed Industrial Storage Areas** with limited natural ventilation
- **Vehicle Movement Zones inside Warehouses** to manage exhaust emissions
- **Smoke Control Systems** for emergency ventilation and safety compliance

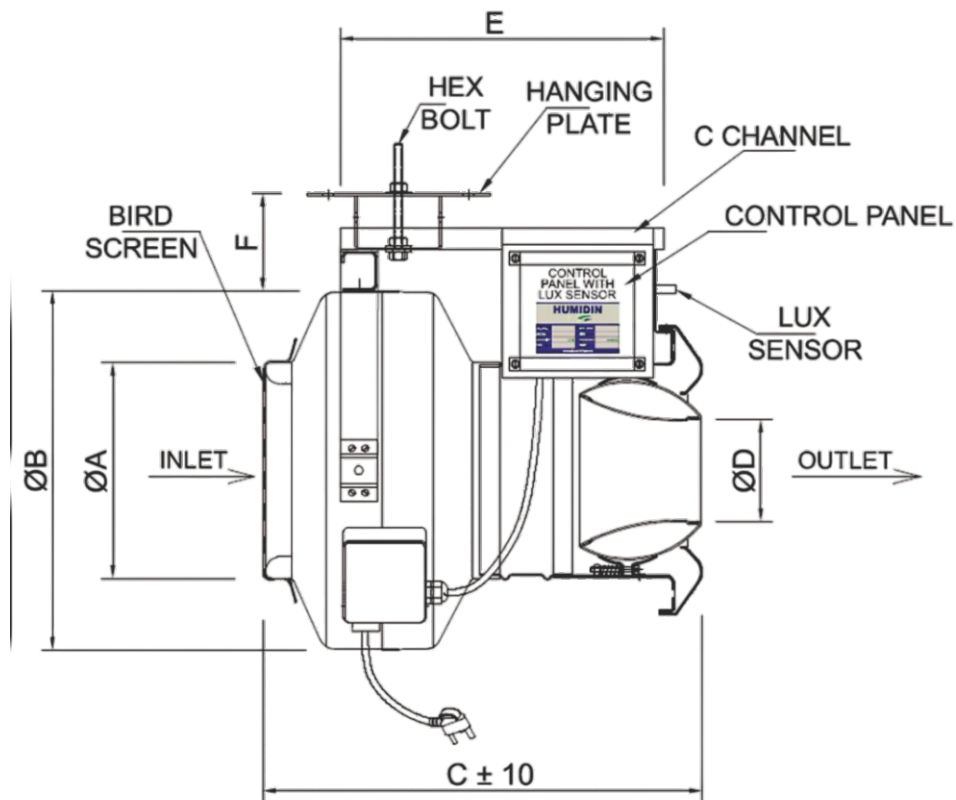

CIRCULAR INLINE JET FAN

Fan Technical				EC - Motor Technical			
Air Volume	AIR VELOCITY	Fan Model	Fan Dia	Motor	Current	Voltage	Frequency
CFM	FPM	Model	mm	Power (W)	AMP	Range	Hz
240	3530	CIL-J 200	200	166	1.37	200-220	50/60
545	2700	CIL-J 315	315	215	1.69	200-220	50/60

NOTE: ALL TECHNICAL & DIMENSIONS ARE ONLY FOR REFERENCE

Dimensions					
A	B	C	D	E	F
mm	mm	mm	mm	mm	mm
200	333	400	94	300	90
315	415	440	160	350	83

HUMIDIN

Sales & Marketing Department

North India: (Ventilation Dept.)

Phone: +91-9654400710

Email Id: tc@humidin.com

East India: (Ventilation Dept.)

Phone: +91-9654551093

Email Id: tceast@humidin.com

West India: (Ventilation Dept.)

Phone: +91-9654551015

Email id: tcwest@humidin.com

South India: (Ventilation Dept.)

Phone: +91-9654781452

Email Id: tcsouth@humidin.com

All India: (Air Handling Unit Dept.)

Phone: +91-9654557807

Email Id: ahu@humidin.com

After Sales Service Department (24x7)

Phone: +91-9654452926

Email Id: service@humidin.com

COUNTRIES:

RIYADH:

Email Id: riyadh@humidin.com

EGYPT:

Email Id: egypt@humidin.com



HR Department

Phone: +91-7290065533

Email Id: hr@humidin.com

hrmanager@humidin.com

Finance Department

Phone: +91-9654452925

Email Id: accounts@humidin.com

The intention of this brochure is to introduce you to, and acquaint you with the capabilities of the HUMIDIN organization in the offered product areas. It will not answer all your immediate questions, and indeed, it will no doubt raise others. We welcome your interest in our products and shall be very pleased to provide further information.

GUARANTEES

HUMIDIN guarantees its products to be free of defects in materials and workmanship for a period of one year from the date of delivery from the factory, provided motors are properly installed with overload protector. Humidin agrees to repair or replace defective parts or part to be returned to the factory, all transportation charges prepaid. Humidin does not guarantee against abrasion, corrosion or erosion. Humidin shall not be held responsible for any charges in connection with the removal or replacement of alleged defective equipment nor for incidental consequential damages

A.C HUMIDIN AIR SYSTEMS PVT.LTD.

Plot C18, Tronica City Industrial Area
Loni Dist. -201102